

# Maximum Performance Contoured Diaphragm Couplings

TRW Aeronautical Systems  
Lucas Aerospace



TRW Lucas Aerospace Couplings offers:

- Best Balance Repeatability
- Lowest Weight
- Highest Reliability
- Ease of Installation
- Stainless Steel Diaphragms

211 Seward Avenue, PO Box 457  
Utica, NY 13503

# TRW Lucas Aerospace Maximum Performance Contoured Diaphragm Couplings

## Proven Technology

- 120,000 Diaphragm Couplings in Service.
- 10 Million hour MTBF.

TRW Lucas Aerospace' (The former Bendix Fluid Power Division) first patent of the contoured diaphragm coupling was in 1949 and after years of research and development the first diaphragm coupling was delivered for an aircraft application in 1955. This aerospace proven technology developed by TRW Lucas Aerospace yielded the most reliable and lightweight approach to transferring torque and misalignment. In 1967 TRW Lucas Aerospace supplied the first contoured diaphragm coupling for use in the industrial petrochemical market. TRW Lucas Aerospace has supplied well over 120,000 contoured diaphragm couplings over the past four decades. Over this time our reliability has been proven with a Mean Time Between Failure (MTBF) of over 10 million operating hours. TRW Lucas Aerospace is the World's Technology Leader for Power Transmission Couplings in the Industrial, Marine and Aerospace Markets. TRW Lucas Aerospace has provided diaphragm couplings in the field from as small as 4 inches in diameter too as large as 80 inches in diameter (See Figure 1).

## TRW Lucas Aerospace Superior Design

- Light weight/simple design.
- Best balance capability.

TRW Lucas Aerospace Couplings have three major parts: a flex unit and two adapters (flange or hub) which interfaces with the driver and load machinery. This simple design only requires two joints and therefore has the best balance repeatability of any coupling. Competing designs require at least four joints and therefore the eccentricity between parts (5 compared to TRW Lucas Aerospace' 3) yields significant more imbalance when a unit is reassembled.

The TRW Lucas Aerospace flex unit has contoured diaphragms located at each end of the spacer and is joined by electron beam (EB) welding. The majority of TRW Lucas Aerospace Couplings are supplied with EB Welded Flex units. TRW Lucas Aerospace has never had radial weld failure. Thorough NDT inspection is completed on each weld to ensure a quality seam.

Each TRW Lucas Aerospace flex unit is coated with multiple layers of Sermetal W, an inorganically (chemically) bonded aluminum

coating, which offers a sacrificial method of corrosion protection. Any area of base material which becomes exposed to a hostile atmosphere is protected by Sermetal coating, which is more chemically reactive than steel, and will be the only surface to corrode. High temperature chemically resistant epoxy paint covers this coating.

TRW Lucas Aerospace leads the industry in sound engineering practice in designing our couplings. Some examples follow:

- Hardware is shrouded to ensure low windage.
- Helicoils are only used on special designs.
- Torque is not transmitted through our bolt threads.
- No holes in flexure areas where bending takes place.
- Wearing and fretting avoided – no loose or rubbing parts.



Figure 1  
88E280 Marine Diaphragm Coupling  
(80 inches in diameter)

That's a Diaphragm!

**TRW Lucas Aerospace:  
The Proven  
Leader for Contoured  
Diaphragm Couplings.**

## Leading the State of The Art

- Custom 455 Stainless Steel.
- Patented Diaphragm.
- New Low Moment.
- API 610 Economic Design.

TRW Lucas Aerospace's stainless steel diaphragm couplings (99/100 Series) have been in the field for over four years. This maximum performance design can't be matched by any other dry coupling of comparable size. Custom 455 stainless steel material has 30% greater strength than 15-5 PH with similar corrosion protection properties. TRW Lucas Aerospace Stainless Steel Couplings are, by far, the superior contoured diaphragm on the market.

TRW Lucas Aerospace continues to be on the leading edge of Coupling Technology. Our latest Diaphragm patent optimizes the diaphragm shape to yield the lowest stress for a given application torque and misalignment. Previous to this technology break through all diaphragm sizing was optimized only for torque using Wolff's conventional diaphragm design. Therefore TRW Lucas Aerospace can provide the state of the art technology for a given set of conditions using either design.

TRW Lucas Aerospace' new low moment coupling uses our standard diaphragms welded to the backside of the hub eliminating the need to put the diaphragm on top of the hub. This design will be the future benchmark for having the lowest moment since the coupling half weight will be the lowest for a comparable bore size coupling and smallest centroid distance because of the flex element position. No other coupling manufacturer has our radial weld experience and therefore can not match this design. The customer is asked to verify that sufficient clearance between the bearing housing exist with the diaphragm. This design is ideal for those applications where lateral critical speeds are a concern.

Presently TRW Lucas Aerospace has a patent on our new API 610 & 671 Diaphragm Couplings, where we have developed a non welded joint for lower torque transmitting applications. This joint is still permanent with no additional hardware and therefore has the same balance repeatability of TRW Lucas Aerospace standard design but is more compatible for mass production.

## Design Philosophy

- Analysis proved by test & FEA.

The contoured diaphragm that TRW Lucas Aerospace has originated and refined over the last half century has been proven time and again by field conditions as well as in house testing and analysis. Every aerospace coupling is subjected to 10 million cycles in house at greater operating stresses than the unit will be subjected to in the field. FEA and strain gage testing have been completed for many different programs including the Frame 7E Mechanical Drive Load Diaphragm Couplings. These methods have verified and validated TRW Lucas Aerospace' proprietary computer program for stress analysis and margin evaluation used for our aerospace, marine and industrial products resulting in the industry's highest reliability and lowest direct operating costs. This analysis incorporates the loading conditions as boundary values in exactly the same fashion as Finite Element Analysis (FEA). TRW Lucas Aerospace uses multiple differential equations, which evaluate the diaphragm structure, and completes a numerical integration to develop the stresses in the diaphragm profile.

TRW Lucas Aerospace' computer-based analysis has simplified our engineering effort such that it only takes seconds to determine the stress levels based on customer requirements. The proprietary computer program sizes and completes a data sheet with all coupling characteristics in minutes such that the customer's quote has accurate engineering data provided. When ordering, this same data is generated into drawings, process and parts via our Computer Aided Design (CAD) and Computer Aided Manufacturing (CAM) Systems. Our new computer system releases and tracks each order from entry to shipment ensuring an on time delivery.

## Coupling Ratings

TRW Lucas Aerospace Diaphragm Couplings have been rerated. Using the tables on page 3 and 5 for Maximum Continuous Torque and 125% misalignments (axial and angular) will yield a factor of safety of at least 1.25. Figure 2 shows a modified Goodman diagram for stainless steel (Custom 455). The combined mean stress (steady state torque/axial & speed) and combined alternating stress (bending & cyclic torque/axial) must have the plotted operating point fall within the area under the dotted line. Any point within this area has a minimum factor of safety of 1.25 using the proportional increase method.

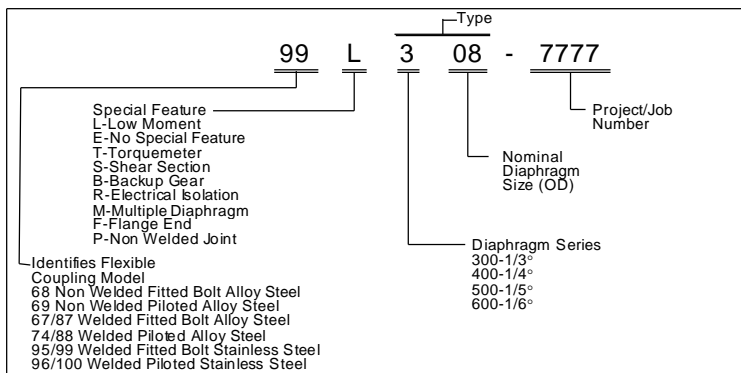

TRW Lucas Aerospace Numbering System

## Life Cycle Cost

- TRW Lucas Aerospace has lowest total system cost.

Thanks to TRW Lucas Aerospace' experience and technology, our Diaphragm Coupling is the most reliable coupling on the market. Because of TRW Lucas Aerospace' infinite life design no spare parts (other than hardware) are required. Therefore the total system cost of the TRW Lucas Aerospace coupling is significantly less than competing designs where downtime to replace a flex element pack will result in added inventory and labor as well as interruption of production revenue.

## Materials

### Hub Flanges

- Forging AISI 4340 or Equivalent
- 130,000 PSI UTS Minimum

### Diaphragms

- Vacuum-Melted AMS 6414 Alloy Steel
- 170,000 PSI UTS Minimum
- Vacuum-Melted AMS 5617 Stainless Steel
- 235,000 PSI UTS Minimum

### Guards

- AISI 4140
- 130,000 PSI UTS Minimum

### Tubes

- AISI 4130, 4340, or Equivalent
- 130,000 PSI UTS Minimum

### Shims

- Low Carbon Steel, Nickel Plated or Stainless Steel

### Bolts

- AISI 4140, 4340, 6150, 8740
- Alloy Steel, Stainless Steel A286
- 150,000-200,000 PSI UTS Minimum

### Nuts

- Alloy Steel, Stainless Steel A286
- 160,000 PSI UTS Minimum

### Protection

- Sermetel
- High Temperature Blue Paint

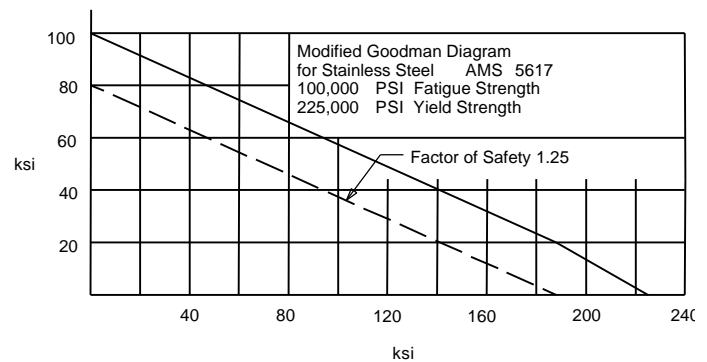

Figure 2 Modified Goodman Diagram

## TRW Lucas Aerospace API 671 Standard & Reduced Moment Couplings

Type Size	High Performance Alloy Steel 87/88 Series		Maximum Performance Stainless Steel 99/100 Series		Misalignment per End (+/- Deg)	Parallel <sup>3</sup> Offset (in./in.)	Limit Speed (RPM)	Coupling <sup>4</sup> OD (in.)	Max <sup>5</sup> Taper Bore B (in.)
	Max <sup>1</sup> Continuous Torque (in-lb.)	Axial <sup>2</sup> Deflection (+/- in.)	Max <sup>1</sup> Continuous Torque (in-lb.)	Axial <sup>2</sup> Deflection (+/- in.)					
305	19,000	0.055	29,000	0.049	0.333	0.0058	35,000	6.055	2.75
405	26,000	0.044	38,000	0.040	0.250	0.0044	40,000	6.055	
505	32,000	0.039	48,000	0.032	0.200	0.0035	45,000	6.055	1.75
605	38,000	0.034	58,000	0.026	0.167	0.0029	50,000	6.055	
306	38,000	0.058	57,000	0.060	0.333	0.0058	28,000	7.055	3.45
406	51,000	0.053	76,000	0.047	0.250	0.0044	33,000	7.055	
506	63,000	0.046	95,000	0.040	0.200	0.0035	38,000	7.055	2.50
606	75,000	0.032	114,000	0.033	0.167	0.0029	43,000	7.055	
308	83,000	0.082	127,000	0.075	0.333	0.0058	23,000	9.175	4.75
408	113,000	0.070	169,000	0.063	0.250	0.0044	28,000	9.175	
508	141,000	0.061	212,000	0.051	0.200	0.0035	33,000	9.175	3.25
608	170,000	0.054	245,000	0.047	0.167	0.0029	35,000	9.175	
310	158,000	0.101	238,000	0.086	0.333	0.0058	20,000	10.930	5.95
410	211,000	0.087	317,000	0.072	0.250	0.0044	25,000	10.930	
510	264,000	0.076	397,000	0.058	0.200	0.0035	28,000	10.930	4.00
610	316,000	0.067	477,000	0.050	0.167	0.0029	30,000	10.930	
312	289,000	0.118	435,000	0.105	0.333	0.0058	19,000	13.050	7.33
412	386,000	0.104	580,000	0.087	0.250	0.0044	22,000	13.050	
512	482,000	0.091	725,000	0.073	0.200	0.0035	25,000	13.050	4.50
612	580,000	0.080	870,000	0.062	0.167	0.0029	27,000	13.050	
314	429,000	0.128	646,000	0.115	0.333	0.0058	17,000	14.805	8.32
414	572,000	0.115	861,000	0.097	0.250	0.0044	20,000	14.805	
514	715,000	0.101	1,076,000	0.081	0.200	0.0035	23,000	14.805	5.00
614	855,000	0.090	1,293,000	0.068	0.167	0.0029	25,000	14,805	
316	682,000	0.136	1,029,000	0.126	0.333	0.0058	15,000	16.805	9.66
416	910,000	0.126	1,373,000	0.107	0.250	0.0044	17,000	16.805	
516	1,138,000	0.112	1,715,000	0.090	0.200	0.0035	20,000	16.805	6.00
616	1,365,000	0.100	2,059,000	0.076	0.167	0.0029	22,000	16.805	
318	925,000	0.162	1,390,000	0.148	0.333	0.0058	14,000	18.805	10.67
418	1,234,000	0.148	1,854,000	0.125	0.250	0.0044	16,000	18.805	
518	1,543,000	0.131	2,317,000	0.106	0.200	0.0035	19,000	18.805	6.87
618	1,851,000	0.116	2,781,000	0.091	0.167	0.0029	21,000	18.805	
322	1,763,000	0.211	2,651,000	0.172	0.333	0.0058	12,000	22.550	13.10
422	2,352,000	0.196	3,535,000	0.148	0.250	0.0044	14,000	22.550	
522	2,938,000	0.154	4,418,000	0.128	0.200	0.0035	16,000	22.550	8.75
622	3,525,000	0.137	5,301,000	0.108	0.167	0.0029	19,000	22.550	

<sup>1</sup> Peak torque is 133% of the maximum continuous torque. Couplings subjected to transient conditions should be evaluated using the Peak torque. Limit torque is 180% of the maximum continuous torque. Couplings subjected to a "one time" momentary load should be evaluated using the Limit torque.

<sup>2</sup> Axial deflection is based on the maximum continuous torque listed. It is possible to trade off axial, torque and rated speed. Contact TRW Lucas Aerospace Engineering for additional information.

<sup>3</sup> Parallel offset equals the value shown multiplied by the distance between flexures.

<sup>4</sup> Nominal dimension is for the piloted units (88 & 100 Series). Fitted bolt units (87 & 99 Series) is 0.360 inches less than tabulated value.

<sup>5</sup> The maximum bore capacity shown are for tapered shaft ends. (Consult Page 5 for straight shaft ends). The first value for each size is for our standard couplings and the second is for our low moment couplings.

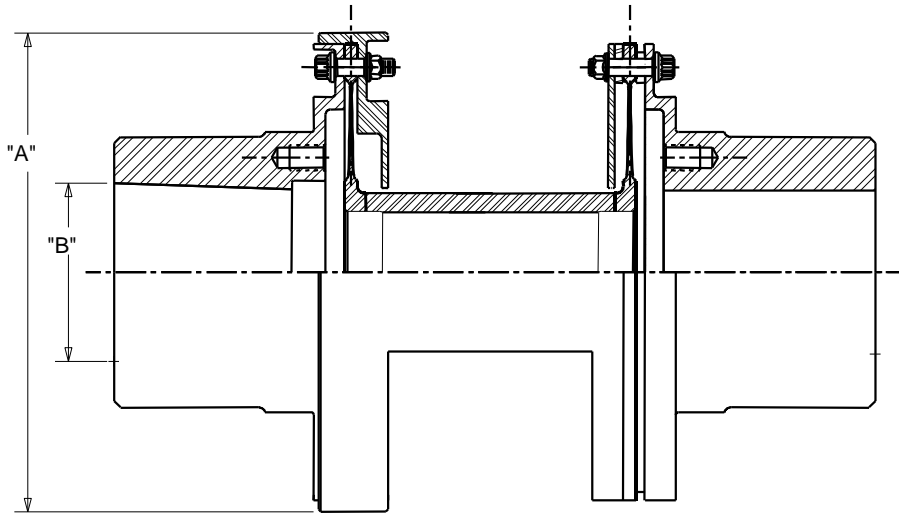

Figure 3 Standard Couplings

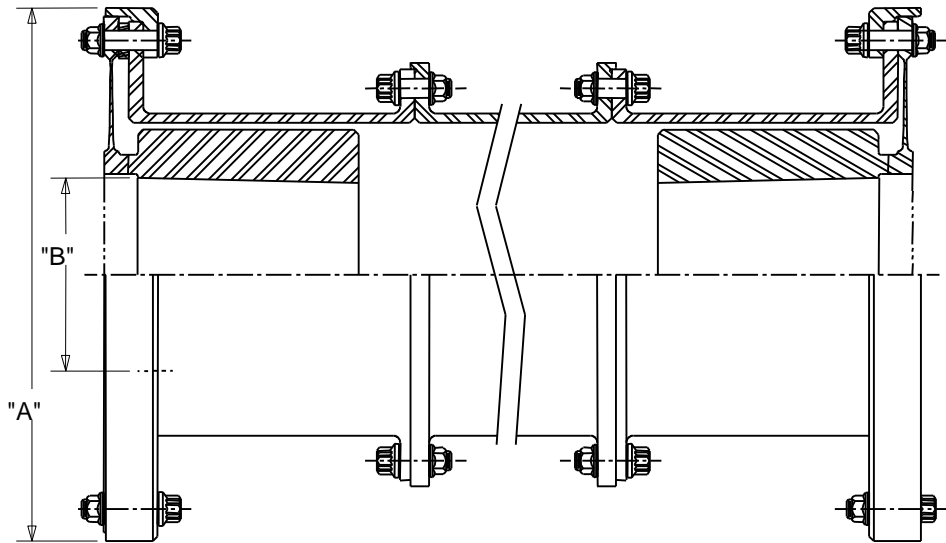

Figure 4 Reduced Moment Couplings

## Lucas API 610 & API 671 Non Welded Standard Couplings Alloy Steel 68/69P Series (Patent Pending)

Type Size	Max <sup>1</sup> Continuous Torque (in.-lb.)	Axial <sup>2</sup> Deflection (+/- in.)	Misalignment per End (+/- Deg)	Parallel <sup>3</sup> Offset (in./in.)	Limit Speed (RPM)	Coupling O.D. A (in.)	Max <sup>4</sup> Straight Bore (in.)
506	50,000	0.035	0.200	0.0035	30,000	6.750	3.00
508	110,000	0.048	0.200	0.0035	25,000	8.800	4.50
510	190,000	0.060	0.200	0.0035	23,000	10.600	6.00
512	360,000	0.074	0.200	0.0035	21,000	12.700	6.50
514	510,000	0.083	0.200	0.0035	19,000	14.500	7.50
516	760,000	0.097	0.200	0.0035	17,000	16.500	8.00
518	1,100,000	0.107	0.200	0.0035	15,000	18.500	9.00
522	2,100,000	0.131	0.200	0.0035	12,000	22.200	10.50

<sup>1</sup> Peak torque is 133% of the maximum continuous torque. Coupling subjected to transient conditions should be evaluated using the Peak torque. Limit torque is 180% of the maximum continuous torque. Couplings subjected to a “one time” momentary load should be evaluated using the Limit torque.

<sup>2</sup> Axial deflection is based on the maximum continuous torque listed. It is possible to trade off axial, torque and rated speed. Contact Lucas Engineering for additional information.

<sup>3</sup> Parallel offset equals the value shown multiplied by the distance between flexures.

<sup>4</sup> The maximum bore capacity shown are for straight shaft ends. (Consult Page 3 for tapered shaft ends).

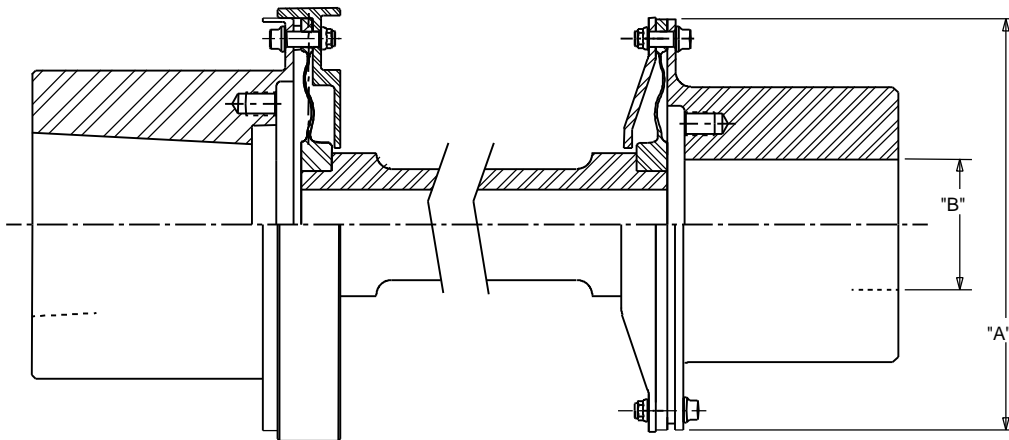

**Figure 5**

## Selection Procedure

### Step 1 - Required Data

Maximum Power \_\_\_\_\_ KW or  
 HP  
 Speed Range \_\_\_\_\_ RPM  
 Trip Speed \_\_\_\_\_ RPM  
 Axial Movement  
 Driver Machine \_\_\_\_\_ Inch  
 Load Machine \_\_\_\_\_ Inch  
 Parallel Offset \_\_\_\_\_ Inch  
 Angular Misalign \_\_\_\_\_ Degrees  
 Distance Between  
 Shaft Ends (BSE) \_\_\_\_\_ Inch  
 Driver Shaft End  
 Dia. (Straight or  
 Taper) \_\_\_\_\_ Inch  
 Load Shaft End  
 Dia. (Straight or  
 Taper) \_\_\_\_\_ Inch  
 Envelope Minimum  
 Diameter \_\_\_\_\_ Inch

### Special Requirements

Torquemeter, Electric Isolation,  
 Shear Section, Backup Gear Drive

API 671 Required [ ] Yes [ ] No  
 API 610 Required [ ] Yes [ ] No

### Step 2 - Torque Calculation

Calculate the normal continuous torque.

$$KW \times 1.341 = HP$$

$$T = \frac{\text{HP} (63,025)}{\text{Speed at which HP occurs}} \text{ Lb-in}$$

For situations where the HP changes over the speed range, the condition generating the maximum continuous torque must be determined.

Electric motor starts, generator short circuit, compressor surge, and pump Cavitation cause single cycle peak torque requirements. This value may mandate a larger coupling selection, based upon the peak torque value of each coupling.

### Step 3 - Coupling Selection

Select the coupling from page 3 or page 5 which has the maximum continuous torque greater than the calculated normal continuous torque with specified application factor.

### Step 4 - Bore Capacity

Verify the maximum bore capacity of the coupling selected is greater than the bores specified.

### Step 5 - Misalignments

Verify that the coupling selected meets the angular and axial misalignments of the application.

### Step 6 - Contact TRW Lucas Aerospace

TRW Lucas Aerospace will supply Coupling Selection Data Sheet in Imperial or SI units; including mass elastic, lateral and axial natural frequencies within 24 hours for standard designs!

## Retrofit Applications

TRW Lucas Aerospace Diaphragm Couplings are used frequently to replace gear, disc and other dry type couplings. Contact TRW Lucas Aerospace with your Retrofit Requirements.

## Balance Standards

TRW Lucas Aerospace has standardized on a method of balance that eliminates the errors associated with arbor balancing:

- Hubs are component balanced on a vertical machine with bores indicated concentric to the rotating table. They are balanced in two planes. Balance journals are ground on the OD of hubs concentric to the hub bore.
- The coupling is assembled with a prebalanced adapter installed within the hub bores. Concentricity of this adapter is maintained using spreader screws. Adjustment screws are used to stretch the diaphragms and rigidize the assembly.
- Alignment involves rotating the coupling on its balance journals and indicating bore diameters. By adjusting adapter screws, hub bores are aligned to within 0.0002 T.I.R. Data recorded during alignment is used to compute the eccentricity which exists between the centerline of balance journals and the actual centerline of the hub bore. This eccentricity is corrected for during the balance operation.

### Degree of Balance

The accompanying formula is used to calculate the balance tolerance per plane for any given coupling. The value of K assigned is usually dependent upon coupling application. The lower the value of K the tighter the balance tolerance.

$$U = \frac{KW}{N}$$

U = Residual Unbalance per Plane  
 (--In-Oz)

W = Plane Weight (--Lb)

N = Max Continuous Operating Speed  
 (--RPM)

K = Constant Denoting Degree of Balance

### Balance Repeatability

The coupling assembly, with its fixtures, is balanced so that the unbalance (expressed as the distance between the coupling's center of gravity and its center of rotation) is very small, generally less than 0.000050 inches.

However, even with the best of care small errors in the relative location of mating parts occur when the coupling is disassembled and then reassembled. These errors often add up to about 0.000400 inch on our couplings.

Thus, when a balanced coupling is checked for repeatability, unbalance values equivalent to  $U \text{ In-Oz} = 0.0064 \times W \text{ lbs}$  can be expected.

To minimize these reassemble errors the TRW Lucas Aerospace couplings:

- Are lightweight.
- Have a minimum number of assembly joints.
- Are matchmarked for consistent assembly.
- Have all machining done before balancing.
- Have no surfaces which wear.
- Are dimensionally stable.
- Have weight-matched bolts and nuts.
- Have zero clearance diametral locating pilots (Models 88 & 100).
- Have close-fitting locating bolts (Models 68, 87 & 99).

## For Further Information Contact

<p>TRW Aeronautical Systems Lucas Aerospace 211 Seward Avenue PO Box 457 Utica, New York 13503 Telephone: 315/793-1418 Fax: 315/793-1415 <a href="http://www.lucasutica.com">http://www.lucasutica.com</a></p> <p>Email: <a href="mailto:ron.sadlon@trw.com">ron.sadlon@trw.com</a></p> <p>NORTH EASTERN UNITED STATES AND ONTARIO CANADA Timothy J. Trautman Company 12168 Creekridge Drive East Aurora, New York 14052 Telephone: 716/652-7260 Fax: 716/652-7261 Email: <a href="mailto:sales@tjtrautmanco.com">sales@tjtrautmanco.com</a></p> <p>SOUTH EASTERN UNITED STATES Lyle Dingman Co. PO Box 568 Seabrook, TX 77586 Telephone: 281/291-0115 Fax: 281/291-0895 Email: <a href="mailto:ldingman@houston.rr.com">ldingman@houston.rr.com</a></p> <p>WESTERN UNITED STATES Southport Equipment Corporation 6914 Canby Avenue PO Box 758 Reseda, California 91337 Telephone: 818/705-8300 Fax: 818/705-8762 Email: <a href="mailto:kbuttkejr@southportequipment.com">kbuttkejr@southportequipment.com</a></p> <p>WESTERN CANADA Solutions4ltd Devon, Alberta Canada T7Y 1E5 Telephone: 780/470-3400 Fax: 780/470-3400 Email: <a href="mailto:sol4@sprint.ca">sol4@sprint.ca</a></p> <p> TRW Aeronautical Systems Lucas Aerospace</p> <p>Revised September 2001 Pub 67U-6-978A</p>	<p>NORTHERN EUROPE ArtsenCrafts bv Minister Lelylaan 1F 2285 HG RIJSWIJK (Z-H) The Netherlands Telephone: 31 70394 1016 Email: <a href="mailto:ArieAartsen@cs.com">ArieAartsen@cs.com</a></p> <p>ITALY P.T.S. s.n.c. di Toselli Lorenzo &amp; C. vai Quaglia, 4 14030 Cerro Tenaro (AT) Italy Telephone: 390 141 409 019 Fax: 390 141 449 900 Email: <a href="mailto:tosellicplgs@alink.it">tosellicplgs@alink.it</a></p> <p>SWITZERLAND Dr Marino Mueller AG Vollkstrasse 22 CH – 8133 Esslingen ZH Switzerland Telephone: 41 1 984 1353 Fax: 41 1 984 0421 Email: <a href="mailto:marino@muellerag.ch">marino@muellerag.ch</a></p> <p>MIDDLE EAST Bin Hilal Enterprises PO Box 7349 Abu Dhabi UAE Telephone: 971 626 8010 Fax: 971 627 5128 Email: <a href="mailto:bhe@emirates.net.ae">bhe@emirates.net.ae</a></p> <p>ASIA TRW Aeronautical Systems Lucas Aerospace Beijing Representative Office Room 1014-1016 Kelun Building 12a Guanghua Road Chaoyang District Beijing 100020 PEOPLES REPUBLIC OF CHINA Telephone: 86-10-6593-4031/2/3/4 Fax: 86-10-6593-4399</p>
--	---